

## Data Sheet

Customer :

Product : Automotive Grade High Power Thin Film Chip Resistors – ARTP..A Series

Size: 0402/0603/0805

Issued Date: 13-Feb-23

Edition : REV. A1



VIKING TECH CORPORATION  
光韻科技股份有限公司

No.70, Guangfu N. Rad.,  
Hsin Chu Industrial Park,  
Hukou Hsiang, Hsin Chu Hsien,  
303, Taiwan

TEL:886-3-5972931

FAX:886-3-5972935•886-3-5973494

E-mail:sales@viking.com.tw

VIKING TECH CORPORATION KAOHSIUNG BRANCH  
光韻科技股份有限公司高雄分公司

No.248-3, Sin-Sheng Rd., Cian-Jhen Dist., Kaohsiung,  
806, Taiwan

TEL:886-7-8217999

FAX:886-7-8228229

E-mail:sales@viking.com.tw

Viking Electronics (WUXI) CO., LTD.  
光韻電子(無錫)有限公司

No.1A,(Xixia Road),Machinery & Industry Park,  
National Hi-Tech Industrial Development Zone of  
Wuxi, Wuxi, Jiangsu Province, China

Zip Code:214028

TEL:86-510-85203339

FAX:86-510-85203667•86-510-85203977

E-mail:wuxisales@tmtec.com.tw

Produced by (QC)	Checked (QC)	Approved by (QC)	Prepared by (Sales)	Accepted by (Customer)
13-Feb-23	13-Feb-23	13-Feb-23		
<b>Chun</b>	<b>Ben Chang</b>	<b>Ben Chang</b>		

## Automotive Grade High Power Thin Film Chip Resistors (ARTP..A Series)



### ■ Features

- Operating temperature up to 175°C for 1000 hr
- Rated dissipation up to 0.4 W for size 0805
- AEC-Q200 Compliance
- Superior temperature cycling robustness
- Advanced sulfur resistance verified according to ASTM B 809

### ■ Applications

- Automotive
- Industrial
- High power and high temperature applications
- Replacement for larger case sizes

### ■ Construction

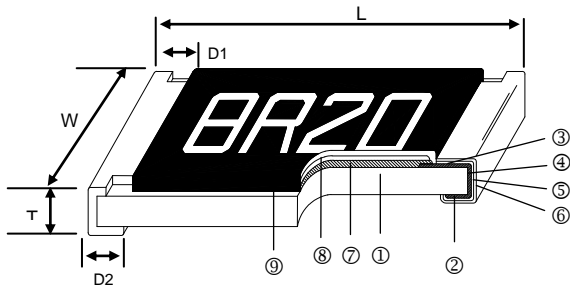

① Alumina Substrate	④ Edge Electrode	⑦ Resistor Layer
② Bottom Electrode	⑤ Barrier Layer	⑧ Overcoat
③ Top Electrode	⑥ External Electrode	⑨ Marking

### ■ Dimensions

Unit: mm

Type	Size (Inch)	L	W	T	D1	D2	Weight (g) (1000pcs)
ARTP02	0402	1.00±0.05	0.50±0.05	0.30±0.05	0.20±0.10	0.20±0.10	0.54
ARTP03	0603	1.55±0.10	0.80±0.10	0.45±0.10	0.30±0.20	0.30±0.20	1.83
ARTP05	0805	2.00±0.15	1.25±0.15	0.55±0.10	0.30±0.20	0.40±0.20	4.71

### ■ Part Numbering

ARTP	05	F	T	C		1001	A
Product Type	Dimensions (LxW)	Resistance Tolerance	Packaging Code	TCR (PPM/°C)	Power Rating	Resistance	Marking Code
	02: 0402 03: 0603 05: 0805	B: ±0.1% D: ±0.5% F: ±1%	T: Taping Reel B: Bulk	C: ±25 D: ±50	: Standard	0100: 10Ω 10R2: 10.2Ω 1000: 100Ω 1001: 1KΩ 1002: 10 KΩ 1003: 100KΩ	A: Automotive Grade

**■ Functional Performance**

**Derating- Power Operation 70**

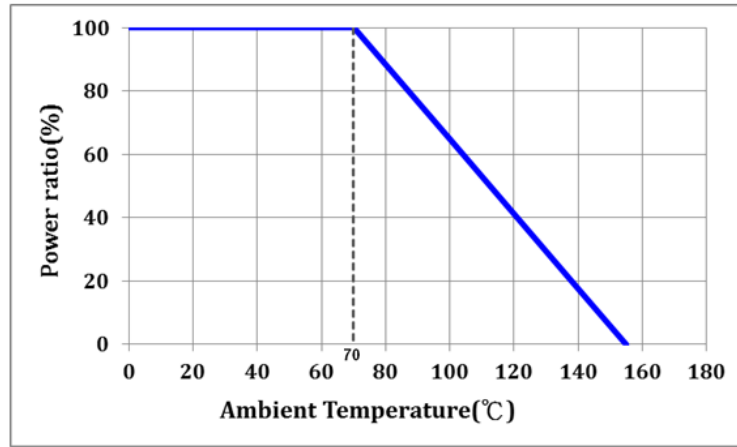

**Derating- Advanced Power Operation**

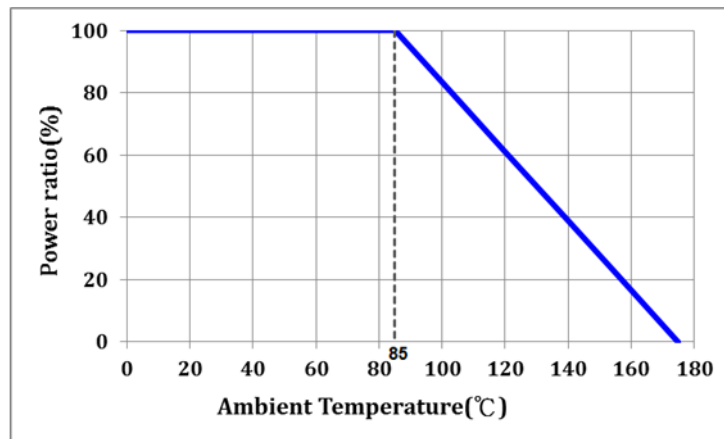

**Functional Performance**

**Single pulse**

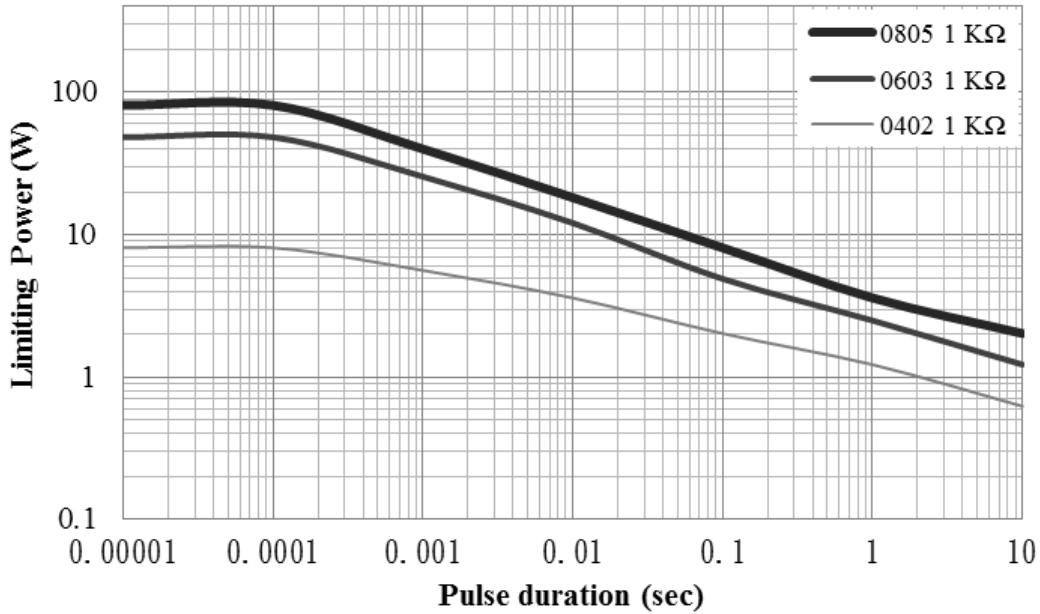

**Pulse Voltage**

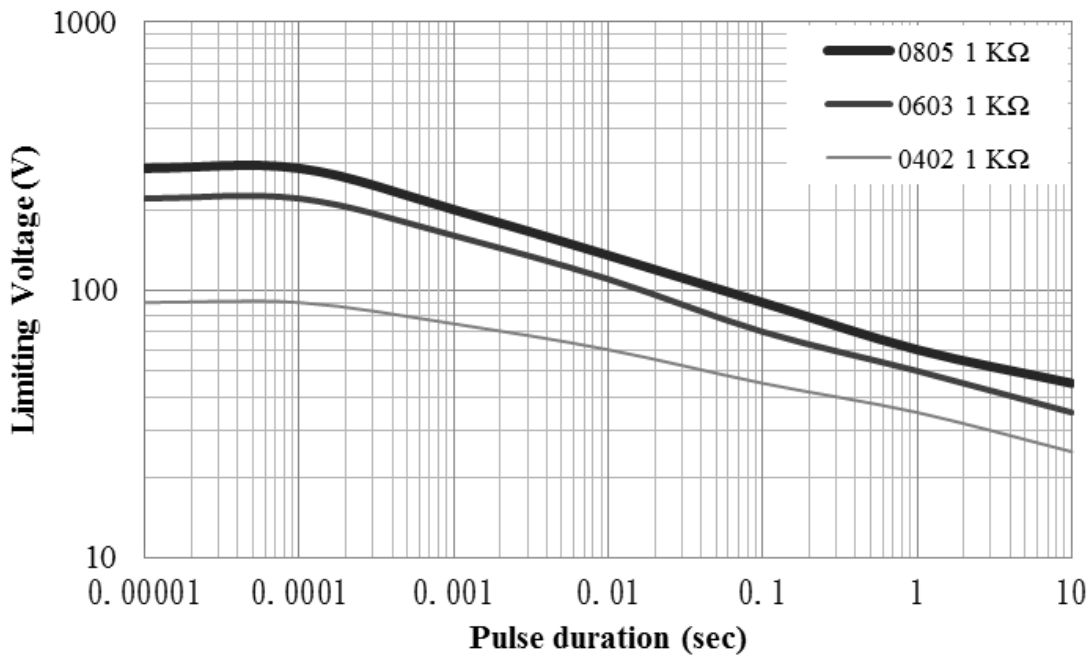

**Standard Electrical Specifications**

Type	Item	Power Rating at 85°C	Operating Temp. Range	Max. Operating Voltage	Max. Overload Voltage	Resistance Range			TCR (PPM/°C)
						±0.1%	±0.5%	±1%	
ARTP02		1/5W		50V	100V	47Ω – 100KΩ			±25
						47Ω – 100KΩ			±50
ARTP03		1/4W	-55 ~ +175°C	75V	150V	47Ω – 100KΩ	10Ω – 100KΩ		±25
						—	10Ω – 100KΩ		±50
ARTP05		2/5W		150V	300V	47Ω – 100KΩ	10Ω – 100KΩ		±25
						—	10Ω – 100KΩ		±50

**Maximum Resistance Change at Rated Dissipation**

Operation Mode		Power P <sub>70</sub>	Advanced Temperature P <sub>85</sub>
Rated dissipation	ARTP02	0.200W	0.200W
	ARTP03	0.250W	0.250W
	ARTP05	0.400W	0.400W
Operating temperature range		-55 ~ 155°C	-55 ~ 175°C
Permissible film temperature		155°C	175°C
Max. resistance change at rated dissipation for resistance range,  ΔR/R  after:	ARTP02	47Ω – 100KΩ	47Ω – 100KΩ
	ARTP03	10Ω – 100KΩ	10Ω – 100KΩ
	ARTP05	10Ω – 100KΩ	10Ω – 100KΩ
	1000hr	≤ 0.2%	≤ 0.3%
	8000hr	≤ 0.4%	—

Operating Voltage= $\sqrt{P \cdot R}$  or Max. operating voltage listed above, whichever is lower.  
 Overload Voltage= $2.5 \cdot \sqrt{P \cdot R}$  or Max. overload voltage listed above, whichever is lower.  
 ■Viking is capable of manufacturing the optional spec based on customer's requirement.

**Environmental Characteristics**

Item	Requirement		Test Method
Temperature Coefficient of Resistance (T.C.R.)	As Spec.		<b>MIL-STD-202 Method 304</b> +25/-55/+25/+125/+25°C
Short Time Overload (Power operation mode)	ΔR±0.25%		<b>JIS-C-5201-1 4.13</b> RCWV*2.5 or Max. overload voltage whichever is lower for 5 seconds
Insulation Resistance	>1000 MΩ		<b>MIL-STD-202 Method 302</b> Apply 100V <sub>DC</sub> for 1 minute
Endurance	Power at 70 °C	1000hrs	<b>MIL-STD-202 Method 108</b> RCWV with 1.5 hrs "ON" and 0.5 hrs "OFF" 1000 hrs
		8000hrs	
	Advanced temperature at 85°C	1000hrs	
High Temperature Exposure	ΔR±0.20%	+155°C	<b>MIL-STD-202 Method 108</b> 1000 hrs
	ΔR±0.30%	+175°C	
Temperature Cycling	ΔR±0.25%		<b>JESD22 Method JA-104</b> -55°C to +155°C, 1000 cycles
Biased Humidity	Power operation mode ΔR±0.5%		<b>MIL-STD-202 Method 103</b> 1000hrs 85°C/85%RH 10% of operating power (≤ 100 V)
Bending Strength (Board Flex)	ΔR±0.1%		<b>JIS-C-5201-1 4.33</b> Bending once for 60 seconds Bending displacement: 0402 0603 0805 sizes: 3 mm
Solderability	95% min. coverage		<b>JIS-C-5201-1 4.17</b> <b>IEC-60115-1 4.17</b> 245±5°C for 3 seconds
Resistance to Soldering Heat	ΔR±0.1%		<b>JIS-C-5201-1 4.18</b> <b>IEC-60115-1 4.18</b> 260±5°C for 10 seconds
Terminal strength	No broken		<b>AEC-Q200-006</b> Force of 1.8kg for 60 seconds.
Mechanical Shock	ΔR±0.1%		<b>MIL-STD-202 Method 213</b> Wave Form: Tolerance for half sine shock pulse. Peak value is 100g's. Normal duration (D) is 6.
Vibration	ΔR±0.1%		<b>MIL-STD-202 Method 204</b> 5 g's for 20 min., 12 cycles each of 3 orientations, 10-2000 Hz
ESD	ΔR±0.5%		<b>AEC-Q200-002</b> Human body model 0402: 0.4KV ; 0603: 0.5KV ; 0805: 1.5KV
Resistance to solvents	Marking Unsmearred		<b>MIL-STD-202 Method 215</b> Add Aqueous wash chemical - OKEM Clean or equivalent. Do not use banned solvents.
Flammability	No ignition of the tissue paper or scorching or the pinewood board		<b>UL-94</b> V-0 or V-1 are acceptable. Electrical test not required.

RCWV(Rated continuous working voltage)= √(P\*R) or Max. Operating voltage whichever is lower

■ **Storage Temperature: 15~28°C; Humidity < 80%RH**

■ **Shelf Life: 2 years from production date.**

**■Soldering Condition(IPC/JEDEC J-STD-020)**

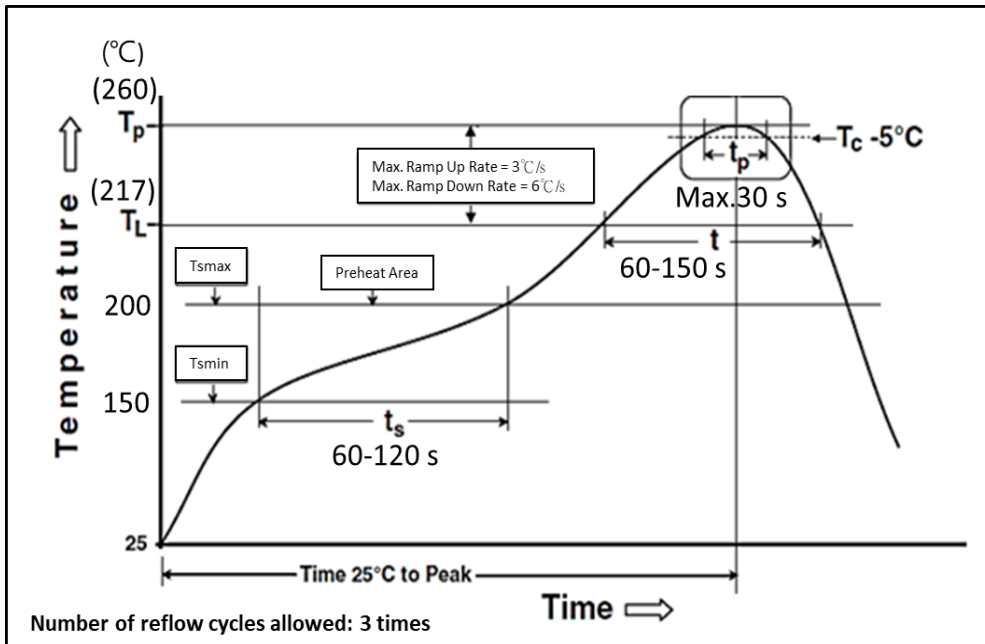

Reflow Profiles	
Profile Feature	Pb-Free Assembly
<b>Preheat</b>	
Min. Temperature ( $T_{smin}$ )	150 °C
Max Temperature ( $T_{smax}$ )	200 °C
Preheating time ( $t_s$ ) from ( $T_{smin}$ to $T_{smax}$ )	60-120 seconds
Ramp-up rate ( $T_L$ to $T_p$ )	3 °C/second max.
Liquidous temperature ( $T_L$ )	217 °C
Time ( $t_L$ ) maintained above $T_L$	60-150 seconds
Min. Peak temperature ( $T_p$ min)	235°C
Max. Peak temperature ( $T_p$ max)	260°C
Time ( $t_p$ ) within 5 °C of the specified classification temperature ( $T_c$ )	30 seconds max.
Ramp-down rate ( $T_p$ to $T_L$ )	6 °C/second max.
Time 25 °C to peak temperature	8 minutes max.

**■ Marking**

0603 3digit marking

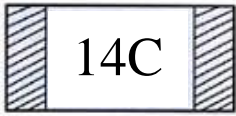

3digit marking for Example: 14C=13K7Ω 13C=13K3Ω  
68B=4K99Ω 68X=49.9Ω

0603 3digit marking for E24

Example: 101=100Ω 102=1KΩ

E24	10	11	12	13	15	16	18	20	22	24	27	30	33	36	39	43	47	51	56	62	68	75	82	91
-----	----	----	----	----	----	----	----	----	----	----	----	----	----	----	----	----	----	----	----	----	----	----	----	----

0805 4digit marking

Example

Resistance	100Ω	2.2KΩ	10KΩ	49.9KΩ	100KΩ
marking	1000	2201	1002	4992	1003

**Marking Table**

Code	E96	Code	E96	Code	E96	Code	E96				
01	100	25	178	49	316	73	562				
02	102	26	182	50	324	74	576				
03	105	27	187	51	332	75	590				
04	107	28	191	52	340	76	604				
05	110	29	196	53	348	77	619				
06	113	30	200	54	357	78	634				
07	115	31	205	55	365	79	649				
08	118	32	210	56	374	80	665				
09	121	33	215	57	383	81	681				
10	124	34	221	58	392	82	698				
11	127	35	226	59	402	83	715				
12	130	36	232	60	412	84	732				
13	133	37	237	61	422	85	750				
14	137	38	243	62	432	86	768				
15	140	39	249	63	442	87	787				
16	143	40	255	64	453	88	806				
17	147	41	261	65	464	89	825				
18	150	42	267	66	475	90	845				
19	154	43	274	67	487	91	866				
20	158	44	280	68	499	92	887				
21	162	45	287	69	511	93	909				
22	165	46	294	70	523	94	931				
23	169	47	301	71	536	95	953				
24	174	48	309	72	549	96	976				
Code	A	B	C	D	E	F	G	H	X	Y	Z
Multiplier	10 <sup>0</sup>	10 <sup>1</sup>	10 <sup>2</sup>	10 <sup>3</sup>	10 <sup>4</sup>	10 <sup>5</sup>	10 <sup>6</sup>	10 <sup>7</sup>	10 <sup>-1</sup>	10 <sup>-2</sup>	10 <sup>-3</sup>



**■Packaging**

Packing Quantity & Reel Specifications

Unit :mm

Type	ØA	ØB	ØC	W	T	Paper Tape (EA)	Emboss Plastic Tape (EA)
ARTP02	178.0±1.0	60.0±1.0	13.5±0.7	9.5±1.0	11.5±1.0	10,000	-
ARTP03	178.0±1.0	60.0±1.0	13.5±0.7	9.5±1.0	11.5±1.0	5,000	-
ARTP05	178.0±1.0	60.0±1.0	13.5±0.7	9.5±1.0	11.5±1.0	5,000	-

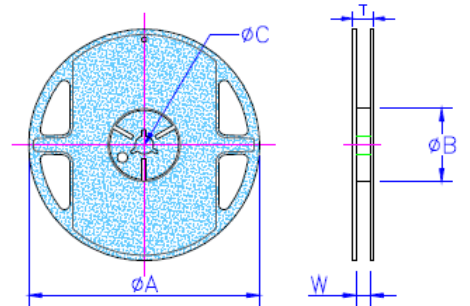

Paper Tape Specifications

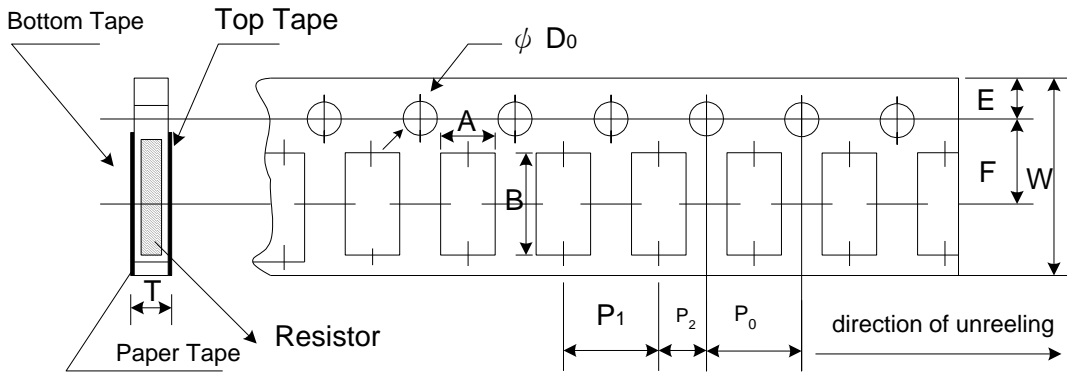

Unit: mm

Type	A	B	W	E	F	P <sub>0</sub>	P <sub>1</sub>	P <sub>2</sub>	ØD <sub>0</sub>	T
ARTP02	0.70±0.05	1.16±0.05	8.00±0.10	1.75±0.05	3.5±0.05	4.00±0.10	2.00±0.05	2.00±0.05	1.55±0.05	0.40±0.03
ARTP03	1.10±0.05	1.90±0.05	8.00±0.10	1.75±0.05	3.5±0.05	4.00±0.10	4.00±0.10	2.00±0.05	1.55±0.05	0.60±0.03
ARTP05	1.60±0.05	2.37±0.05	8.00±0.10	1.75±0.05	3.5±0.05	4.00±0.10	4.00±0.10	2.00±0.05	1.55±0.05	0.75±0.05

- Peel force of top cover tape
- The peel speed shall be about 300mm/min±5%
- The peel force of top cover tape shall be between 8gf to 60gf

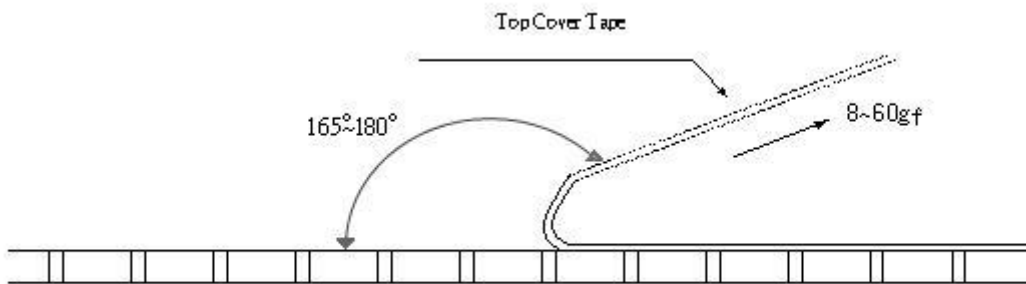

**■Recommend Land Pattern**

Unit: mm

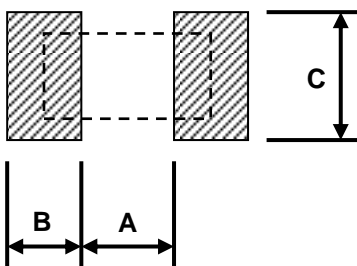

Type	A	B	C
ARTP02	0.50	0.50	0.60±0.2
ARTP03	0.80	1.00	0.90±0.2
ARTP05	1.00	1.00	1.35±0.2